

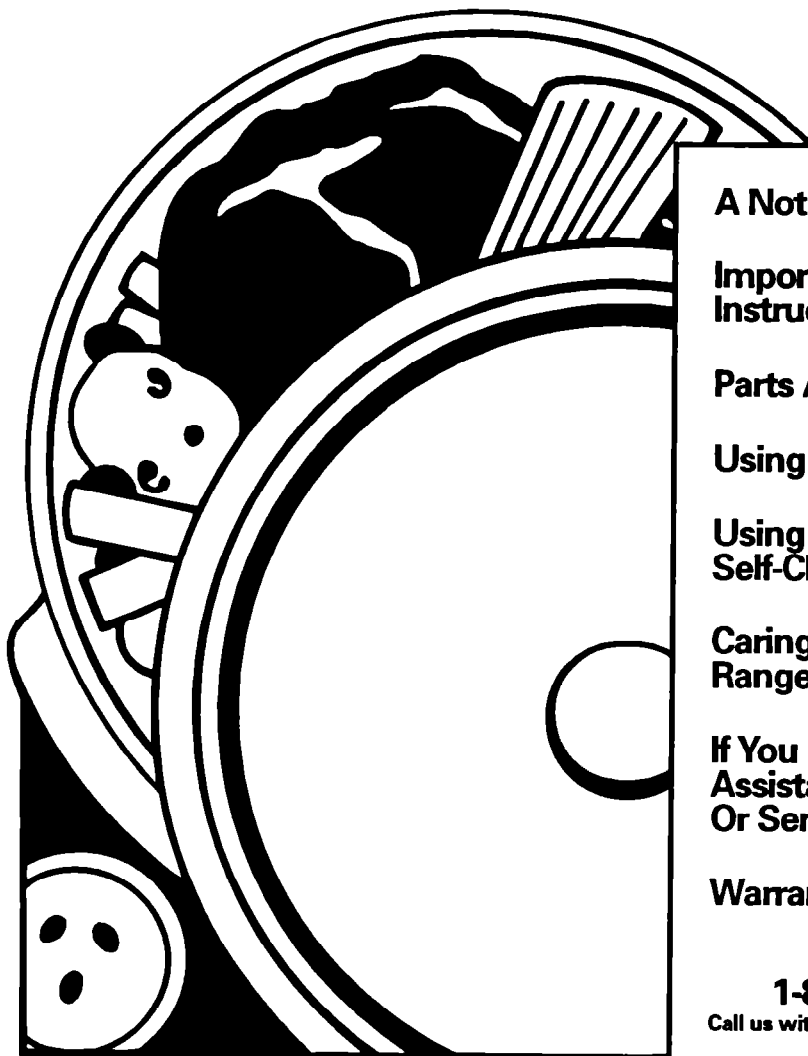

HOW TO MAKE A HOME RUN.™

Use And Care

GUIDE



A Note To You	2
Important Safety Instructions	3
Parts And Features	6
Using Your Range	7
Using The Self-Cleaning Cycle	30
Caring For Your Range	35
If You Need Assistance Or Service	41
Warranty	44

1-800-253-1301
Call us with questions or comments.

SELF-CLEANING GAS RANGE

TO THE INSTALLER: PLEASE LEAVE THIS INSTRUCTION BOOK WITH THE UNIT.

TO THE CONSUMER: PLEASE READ AND KEEP THIS BOOK FOR FUTURE REFERENCE.

**MODELS SF387PEY
SF387PCY**

7/94

A NOTE TO YOU

A Note To You

Thank you for buying a Whirlpool® appliance.

Because your life is getting busier and more complicated, Whirlpool ranges are easy to use, save time, and help you manage your home better. To ensure that you will enjoy years of trouble-free operation, we developed this Use and Care Guide. It is full of valuable information on how to operate and maintain your appliance properly and safely. Please read it carefully. Also, please complete and mail the Ownership Registration Card provided with your appliance. This will help us notify you about any new information on your appliance.

Your safety is important to us.

This guide contains safety symbols and statements. Please pay special attention to these symbols and follow any instructions given. Here is a brief explanation of the use of each symbol.

⚠ WARNING

This symbol will help alert you to such dangers as personal injury, burns, fire and electrical shock.

⚠ CAUTION

This symbol will help you avoid actions which could cause product damage (scratches, dents, etc.) and damage to your personal property.



⚠ WARNING

- ALL RANGES CAN TIP.
- INJURY TO PERSONS COULD RESULT.
- INSTALL ANTI-TIP DEVICES PACKED WITH RANGE.
- SEE INSTALLATION INSTRUCTIONS.

For more information, see the "The anti-tip brackets" on page 29.

Our Consumer Assistance Center number, 1-800-253-1301, is toll-free, 24 hours a day.

If you ever have a question concerning your appliance's operation, or if you need service, first see "If You Need Assistance Or Service" on page 41. If you need further help, feel free to call our Consumer Assistance Center. When calling, you will need to know your appliance's complete model number and serial number. You can find this information on the model and serial number plate (see diagram on page 6). For your convenience, we have included a handy place below for you to record these numbers, the purchase date from the sales slip and your dealer's name and telephone number. Keep this book and the sales slip together in a safe place for future reference.

Model Number _____

Dealer Name _____

Serial Number _____

Dealer Phone _____

Purchase Date _____

IMPORTANT SAFETY INSTRUCTIONS

Important Safety Instructions

READ AND SAVE THESE INSTRUCTIONS

Gas ranges have been thoroughly tested for safe and efficient operation. However, as with any appliance, there are specific installation and safety precautions which must be followed to ensure safe and satisfactory operation.

⚠ WARNING

To reduce the risk of fire, electrical shock, injury to persons, or damage when using the range, follow basic precautions, including the following:

WARNING: If the information in this manual is not followed exactly, a fire or explosion could result causing property damage, personal injury or death.

Do not store or use gasoline or other flammable vapors and liquids in the vicinity of this or any other appliance.

WHAT TO DO IF YOU SMELL GAS:

- Do not try to light any appliance.
- Do not touch any electrical switch; do not use any phone in your building.
- Immediately call your gas supplier from a neighbor's phone. Follow the gas supplier's instructions.
- If you cannot reach your gas supplier, call the fire department.

Installation and service must be performed by a qualified installer, service agency or the gas supplier.

General

- Install or locate the range only in accordance with the provided Installation Instructions. The range must be installed by a qualified installer. The range must be properly connected to the proper gas supply and checked for leaks. The range must also be properly connected to electrical supply and grounded.
- Gas fuels and their use in appliances can cause minor exposures to benzene, formaldehyde, carbon monoxide and soot, primarily from incomplete combustion. Significant exposure to these substances could cause cancer or reproductive harm. Properly adjusted burners with a blue, rather than a yellow, flame will minimize incomplete combustion. Venting with a hood or an open window will further minimize exposure.

continued on next page

IMPORTANT SAFETY INSTRUCTIONS

- Do not store things children might want above the range. Children could be burned or injured while climbing on it.
- Do not leave children alone or unattended in area where the range is in use. They should never be allowed to sit or stand on any part of the range. They could be burned or injured.
- Do not operate the range if it is damaged or not working properly.
- Do not use the range for warming or heating the room. Persons could be burned or injured, or a fire could start.
- Do not attempt to light the oven burner during a power failure. Personal injury could result. Reset oven controls to the off position in the event of a power failure.
- Use the range only for its intended use as described in this manual.



- Do not touch surface burners, areas near surface burners or interior surfaces of oven. Areas near surface burners and interior surfaces of an oven become hot enough to cause burns. During and after use, do not touch, or let clothing or other flammable materials contact surface burners, areas near surface burners or interior surfaces of oven until they have had sufficient time to cool. Other surfaces of the range, such as the oven vent opening, the surface near the vent opening, the cooktop, the oven door and window, could also become hot enough to cause burns.



- Do not wear loose or hanging garments when using the range. They could ignite if they touch an open flame and you could be burned.
- Use only dry potholders. Moist or damp potholders on hot surfaces could result in burns from steam. Do not let potholder touch an open flame. Do not use a towel or bulky cloth for a potholder. It could catch on fire.
- Keep range vents unobstructed.
- Do not heat unopened containers. They could explode. The hot contents could cause burns and container particles could cause injury.
- Do not store flammable materials on or near the range. The fumes could create an explosion and/or fire hazard.
- Do not use the oven for storage.
- Do not use aluminum foil to line burner pans, oven bottom, or any other part of the range. Use aluminum foil only as recommended in this manual.
- Never use a match or other flame to look for a gas leak. Explosion and injury could result.
- Know where your main gas shutoff valve is located.

When using the cooktop

- Make sure the utensils you use are large enough to contain food and avoid boilovers and spillovers. Heavy splattering or spillovers left on a range could ignite and burn you. Pan size is especially important in deep fat frying.
- Check to be sure glass cooking utensils are safe for use on the range. Only certain types of glass, glass-ceramic, ceramic, earthenware or other glazed utensils are suitable for cooktops without breaking due to the sudden change in temperature.

IMPORTANT SAFETY INSTRUCTIONS

- Never leave surface burners unattended at high heat settings. A boilover could result and cause smoking and greasy spillovers that could ignite.



- Turn pan handles inward, but not over other surface burners. This will help reduce the chance of burns, igniting of flammable materials, and spills due to bumping of the pan.
- Do not use decorative covers or trivets over the surface burners.

When using the oven

- Always position the oven rack(s) in desired location while oven is cool.
- Use care when opening oven door. Let hot air or steam escape before removing or replacing food.

Grease

- Grease is flammable. Do not allow grease to collect around cooktop or in vents. Wipe spillovers immediately.



- Do not use water on grease fires. Never pick up a flaming pan. Smother flaming pan by covering with a well-fitted lid, cookie sheet or flat tray. Flaming grease outside of pan can be extinguished with baking soda or, if available, a multipurpose dry chemical or foam-type extinguisher.

Care and cleaning

- Small amounts of formaldehyde and carbon monoxide are given off in the Self-Cleaning cycle from fiberglass insulation and food decomposition. Significant exposure to these substances could cause cancer or reproductive harm. Exposure can be minimized by venting with a hood or open window and wiping out excess food spills prior to self-cleaning.



- Do not use oven cleaners. No commercial oven cleaner or oven liner protective coating of any kind should be used in or around any part of the oven.
- Before self-cleaning the oven, remove broiler pan, broiler grid, oven racks and other utensils. Do not use your oven to clean miscellaneous parts unless you are instructed to do so in this Use and Care Guide.
- Do not clean door heat seal. It is essential for a good seal. Care should be taken not to rub, damage or move the seal. Clean only parts recommended in this Use and Care Guide.
- Do not repair or replace any part of the range unless specifically recommended in this manual. All other servicing should be referred to a qualified technician.
- Any additions, changes or conversions required in order for this appliance to satisfactorily meet the application needs must be made by a Whirlpool® service company or Qualified Agency.
- Disconnect the electrical supply and the gas supply at the shutoff valve near the range before servicing the range.

– READ AND SAVE THESE INSTRUCTIONS –

PARTS AND FEATURES

Parts And Features

This section contains captioned illustrations of your range. Use them to become familiar with the location and appearance of all parts and features.

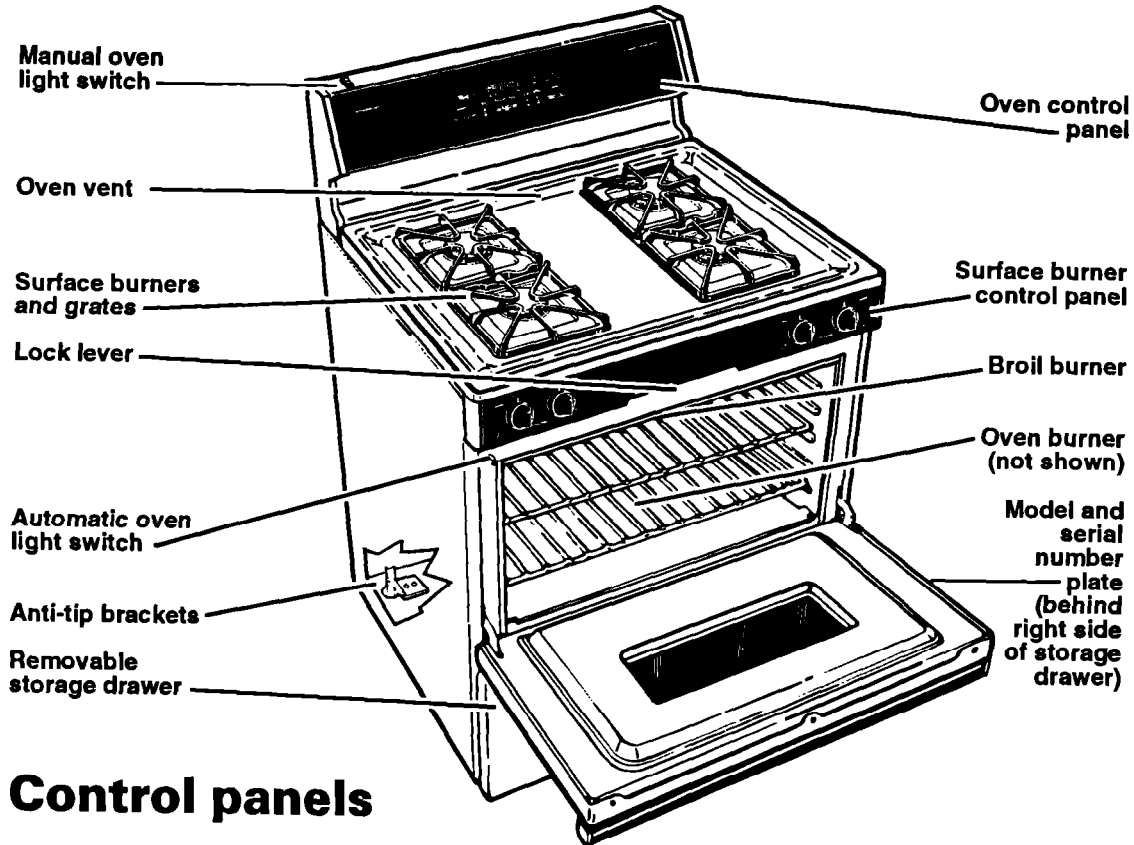

Control panels

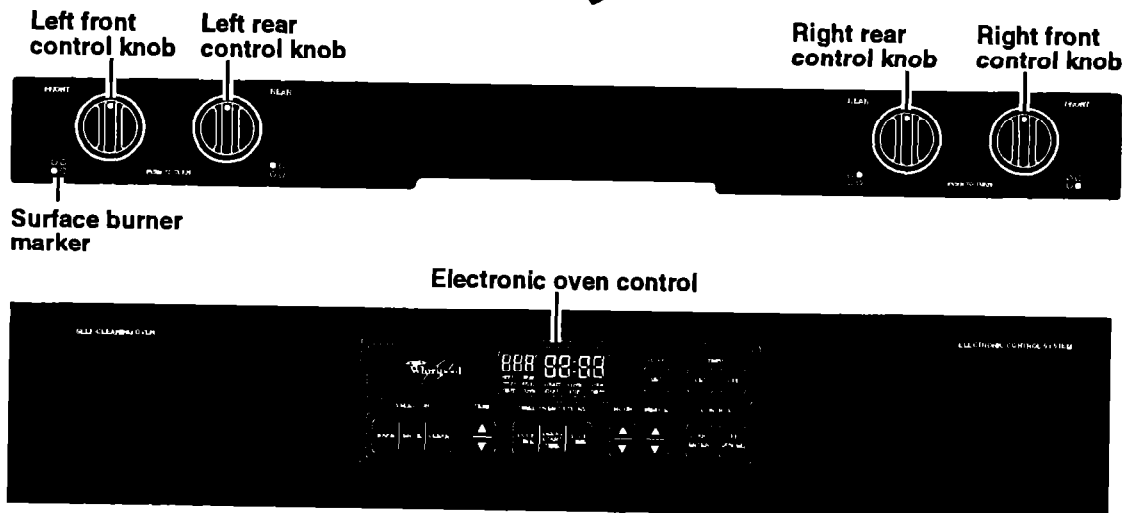

Using Your Range

In This Section		Page	Page
Using the surface burners	7	Adjusting the oven temperature control	15
Positioning racks and pans	9	Broiling	16
For best air circulation	10	Broiling tips	17
The electronic oven control	11	Energy saving tips	18
Setting the clock	12	Using the electronic MEALTIMER™ control	18
Using the electronic Minute Timer ..	12	The oven vent	28
Using the Off/Cancel pad	13	The storage drawer	28
Audible signals	13	The anti-tip brackets	29
Baking/roasting	14		

To obtain the best cooking results possible, you must operate your range properly. This section gives you important information for efficient and safe use of your range.

Using the surface burners

Your range is equipped with electric ignitors. Electric ignitors automatically light the burners each time they are used.

Push in control knob and turn counterclockwise to the LITE position. The clicking sound is the ignitor sparking. **Visually check that burner has lit.**

To stop the clicking sound after the burner lights, turn the control knob to the desired setting. The control knob has stops for HI, MED and LOW. However, you can set the control knob anywhere between HI and OFF.

Surface burner markers

The solid dot in the surface burner marker shows which surface burner is turned on by that knob.

Burner heat settings

Use correct burner heat settings (see next page). If the heat setting is too high, it can:

- **Char** bacon and cause curling.
- **Make** eggs tough and crisp at the edges.
- **Toughen** liver, fish and seafood.
- **Scorch** delicate sauces and custards.
- **Cause** a boilover.

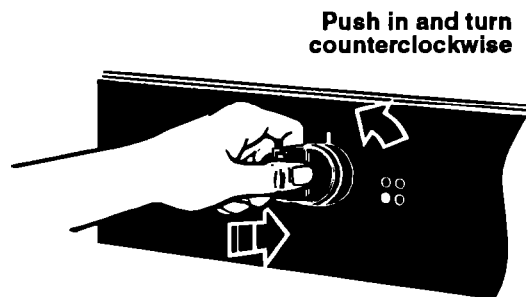

USING YOUR RANGE

Until you get used to the settings, use the following as a guide. For best results, start cooking at the high setting; then turn the control knob down to continue cooking.

SETTING	RECOMMENDED USE
LITE	<ul style="list-style-type: none"> To light the burner. After the burner lights, turn control back to a desired setting to stop the clicking of the ignitor.
HI	<ul style="list-style-type: none"> To start foods cooking. To bring liquids to a boil.
MED	<ul style="list-style-type: none"> To hold a rapid boil. To fry chicken or pancakes. For gravy, pudding and icing. To cook large amounts of vegetables.
LOW	<ul style="list-style-type: none"> To keep food warm until ready to serve.

NOTE: Do not cook with the control in the LITE position.

In case of a prolonged power failure

Surface burners can be manually lighted. Hold a lit match near a burner and turn the control knob to the LITE position. After the burner lights, turn the control knob to the desired setting.

⚠ WARNING

Burn, Fire, and Explosion Hazard

- Burner flame should not extend beyond the edge of the cooking utensil. The flame could burn you and cause poor cooking results.
- Be sure all control knobs are turned to OFF when you are not cooking. Someone could be burned or a fire could start if a burner is accidentally left ON.
- If the flame should go out while cooking, or if there is a strong gas odor, turn the burners OFF. Wait five minutes for the gas odor to disappear before relighting burner. If gas odor is still present, see safety note on page 3. Failure to follow these precautions could result in explosion or fire.

Product Damage Hazard

Do not leave an empty utensil, or one which has boiled dry, on a hot surface burner.

The utensil could overheat and could damage the utensil or cooking product.

Cookware tips

No one brand of cookware is best for all people. Knowing something about pan materials and construction will help you select the correct cookware for your needs.

- **NOTE: For best results and greater fuel efficiency,** use only flat-bottomed cookware in good condition.
- The pan should have straight sides and a tight-fitting lid.
- Choose medium to heavy gauge (thickness) pans that are fairly lightweight.
- The pan material (metal or glass) affects how fast heat transfers from the surface burners through the pan material and how evenly heat spreads over the pan bottom. Choose pans that provide the best cooking results.
- Handles should be made of a sturdy, heat-resistant material and be securely attached to the pan.

- **Pans** should be easy to clean. Check to be sure there are no crevices, rough edges or areas where food might collect.
- **Be sure pans** do not tip, whether they are full or empty.
- **Use cookware** only as it was intended to be used. Follow pan instructions. This is very important for glass cookware because some should be used only in the oven. Other pans are marked as flameware and may be used on the surface burners.

Home canning information

The larger diameter of most water-bath or pressure canners combined with high heat settings for long periods of time can cause damage to the cooktop.

To protect your range:

- **For best results**, use a canner which can be centered over the surface burner.
- **Do not place canner** on two surface burners at the same time. Too much heat will build up and will damage the cooktop.
- **Start with hot water**. This reduces the time the control is set on high. Reduce heat setting to lowest position needed to keep water boiling.
- **Refer to your canner manual** for specific instructions.

Positioning racks and pans

For baking/roasting with one rack, place the rack so the top of the food will be centered in the oven.

Rack placement for specific foods:

FOOD	RACK POSITION
Frozen pies, large roasts, turkeys	1st or 2nd rack guide from bottom
Angel and bundt cakes, most quick breads, yeast breads, casseroles, meats	2nd rack guide from bottom
Cookies, biscuits, muffins, cakes, nonfrozen pies	2nd or 3rd rack guide from bottom

When baking on two racks, arrange racks on first and third rack guides from bottom.

NOTE: For recommended rack placement when broiling, see "Broiling rack position chart" on page 17.

⚠ WARNING

Personal Injury Hazard

- Always position oven rack(s) in desired location before turning oven on. Be sure the rack(s) is level.
- If rack(s) must be moved while oven is hot, use potholders or oven mitts to protect hands.
- Do not place items on the open oven door.
- Be careful when installing and removing large food items from extra roasting rack position. Food will be closer to hot surfaces, including oven bottom and sides.

Failure to follow the above precautions could result in personal injury.

continued on next page

USING YOUR RANGE

Extra oven rack position (roasting rack)

When roasting food too large to be placed in oven with rack in lowest position, place rack on bottom of oven.

For proper roasting, follow these guidelines:

- The rack must be level.
- Use adequate amount of liquid (meat juices or water) so food does not get overdone.
- Do not try to pull rack out over door. Rack will be at the same level as door when door is opened.

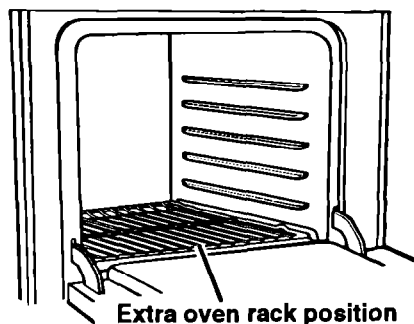

For best air circulation

Hot air must circulate around the pans in the oven for even heat to reach all parts of the oven. This results in better baking.

- Place the pans so that one is not directly over the other.
- For best results, allow 1½-2 inches (4-5 cm) of space around each pan and between pans and oven walls. There must be a minimum space of 1 inch (2.5 cm).
- Use only one cookie sheet in the oven at one time.

Use the following as a guide to determine where to place the pans:

One pan

Place in the center of the oven rack.

Two pans

Place in opposite corners of the oven rack.

Three or four pans

Place in opposite corners on each oven rack. Stagger pans so no pan is directly over another.

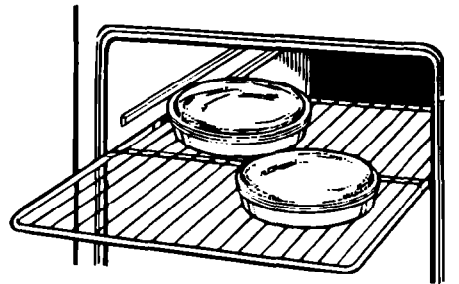

The electronic oven control

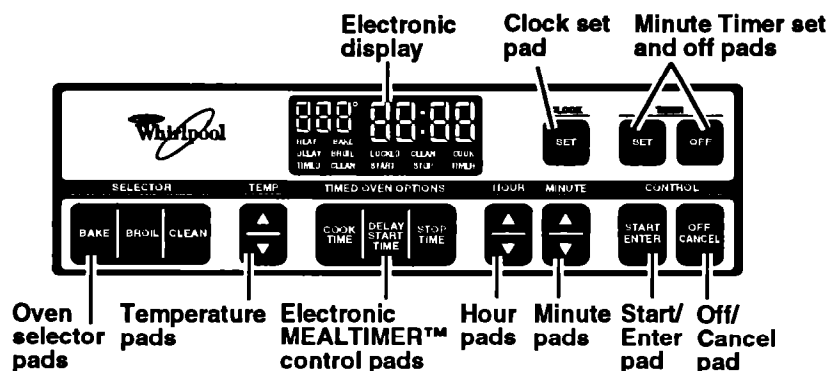

Display/clock

- **When you first plug in the range**, a time of day and "PF" will appear in the temperature display. If, after you set the clock (page 12), "PF" again appears on the display, your electricity was off for a while. Reset the clock.
- **When you are not using the oven**, the control is an accurate clock.
- **When you are using the oven or Minute Timer**, the display will show times, temperature settings and what command pads have been pressed.
- **When showing the time of day**, the display will show the hour and minutes.
- **When you are using the Minute Timer**, the display will show minutes and seconds in the following sequence:
 - **For settings from 1-59 minutes**, the display will count down each second.
 - **For settings 1 hour or over**, the display will count down each minute.
- **When you are using Cook Time and/or Stop Time**, the display will show hours and minutes.

Command pads

The command pads tell the oven what to do and in what order. A few examples:

- **Clock/Set** tells the oven you are going to set the clock.
- **Off/Cancel** tells the oven to turn off.

Each command pad (except Off/Cancel and Start/Enter) has its own Indicator Light. The Indicator Light comes on when you touch the command pad.

Setting the clock

1. Push the Clock/Set pad. The colon flashes and TIME will light up on the display.

CLOCK

SET



2. Use the Hour and Minute pads to set the time of day. Push the “up” (▲) or “down” (▼) pad(s) until the correct time shows on the display.

HOUR MINUTE



3. Push the Start/Enter pad.

NOTE: If you do not want the clock time displayed, push and hold the Clock/Set pad for 4 seconds. To display the clock time again, push the Clock/Set pad once, then reset the clock time if necessary.

START
ENTER

Using the electronic Minute Timer

The Minute Timer does not start or stop the oven. It works like a kitchen timer. It can be set in hours and minutes up to 11 hours, 59 minutes. The Minute Timer will display minutes and seconds for settings under one hour. You will hear four 1-second tones when the set time is up.

1. Push the Timer Set pad. TIMER will come on and the display will show “0:00” with the colon flashing.

TIMER

SET

OFF



2. Use the Hour and Minute pads to set the desired time. Push the “up” (▲) or “down” (▼) pad(s) until the correct time shows on the display.

HOUR MINUTE



USING YOUR RANGE

3. Push the Start/Enter pad. The Minute Timer will begin counting down immediately after the timer is started.

When time is up, "End" will show in the large display and you will hear four 2-second tones. You will also hear four 1-second tones every minute until you push one of the two Timer pads.

NOTE: To disable the reminder tones, push and hold the Timer Set pad for 4 seconds. To reactivate the tones, follow the same procedure.



To cancel the Minute Timer:

- Push the Timer Off pad. The time of day will show in the display.

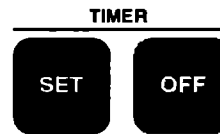

Using the Off/Cancel pad

The Off/Cancel pad will cancel any function except for the Clock/Set and Timer Set functions. When you push the Off/Cancel pad, the display will show the time of day or, if Minute Timer is also being used, the time remaining.



Audible signals

Audible signals tell you if a function is entered correctly or not. They also tell you when a cycle is completed.

To shut off all signals except for the end-of-timer tone:

Press and hold the Stop Time pad for 4 seconds. A short tone will sound to tell you the signals have been changed.

Repeat the above step to turn the signals back on.

Baking/roasting

NOTE: Do not attempt to light the oven burner during a power failure. See "Important Safety Instructions" on page 4 for more information.

1. **Position** the rack(s) properly before turning on the oven. **To change rack position, lift rack at front and pull out.** For further information, see "Positioning racks and pans" on page 9.
2. **Push** the Bake pad. "350°" will show on the small display to indicate the preset temperature and BAKE will light up.



3. **To cook at a different temperature, use** the Temp pad(s). **Push ▲** to raise the temperature or ▼ to lower the temperature in 5°F increments. **Use** these pads until the desired temperature shows on the small display.



4. **Push** the Start/Enter pad. "Lo", HEAT and BAKE show on the display to indicate that the oven is preheating. The temperature will increase in 5° increments.



NOTE: The display will show "door" and a tone will sound once a minute for 5 minutes if the door is latched when you try to bake/roast.

You can change the temperature setting any time after pushing the Start/Enter pad by pushing just the Temp pad(s).



5. **When baking, preheat** the oven. (Preheating is not needed when roasting.) The oven is preheated when you hear a one-second tone and HEAT goes off.
6. **Put food in the oven.** During baking/roasting, the oven burner will turn on and off to keep the oven temperature at the setting.

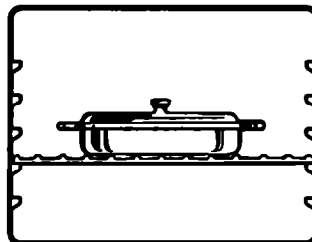

- 7. When baking/roasting is done, push the Off/Cancel pad. The time of day will show on the display and all other displays will go off.**



Adjusting the oven temperature control

Oven temperature controls will gradually shift after years of use. So, even though your new oven is properly adjusted to provide accurate temperatures, it may cook faster or slower than your old oven.

If, after using the oven for a period of time, you are not satisfied with the temperature settings, you can adjust them by following these steps:

- 1. Push the Bake pad and hold (for about 4 seconds) until the time display shows the current temperature offset, for example "00" if you have not previously adjusted the temperature.**
- 2. To adjust the temperature, use the Temp pad(s). Push ▲ to raise the temperature or ▼ to lower the temperature in 5°F increments. You can set the temperature change to as low as -35°F or as high as +35°F. A minus (-) sign will appear before the number when decreasing the temperature setting to show the oven will be cooler by the displayed amount.**
- 3. After making the desired adjustment, push any command pad to enter the new offset temperature.**

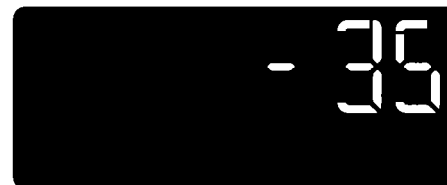

Broiling

1. **Position** the rack before turning the oven on. See "Broiling rack position chart" on page 17.
2. **Preheat** the broiler for 5 minutes before using.
3. **Push** the Broil pad. The small display will show "HI". The time of day and BROIL will light up.

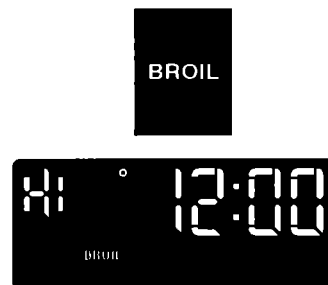

4. **Push** the Start/Enter pad. HEAT, BROIL and "HI" show on the display. The broiler will automatically light in 50-60 seconds.

NOTE: The display will show "door" and a tone will sound once a minute for 5 minutes if the door is latched when you try to broil.

You can change the temperature setting any time after pushing the Start/Enter pad by pushing just the Temp pad(s).

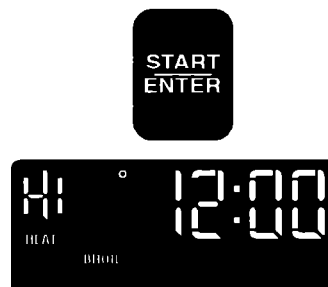

5. **After preheating**, put the broiler pan and food on the rack.
6. **Completely close** the oven door to ensure proper broiling temperatures.
7. **When broiling is done**, push the Off/Cancel pad. The time of day will show on the display and all other displays will go off.

To broil at a lower temperature:

- If food is cooking too fast, push the Broil pad and push the ▼ Temp pad until "Lo" shows on the small display.
- If you want food to broil slower from the start, push the Broil pad and push the ▼ Temp pad so a "Lo" setting shows on the small display. This burner setting allows the broil burner to cycle and provides slow cooking. BROIL and HEAT will light up on the display.
- **Fish and chicken** are some foods that may cook better if you use lower broiling temperatures.

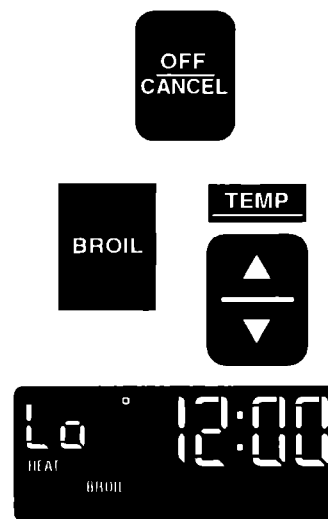

Broiling tips

- **Use** the broiler pan and grid for broiling. They are designed to drain excess liquid and grease away from the cooking surface to help prevent spatter, smoke or fire.
- **If you broil small quantities**, you may want to use a small broiler pan. They are available in the housewares section of many department stores.
- **For best broiling results**, preheat at "HI" for 5 minutes. Do not preheat with broiler pan in place.
- **Broiling rack position** determines how the burner cooks your food. The lower the position, the more broiler grid area covered. See "Broiling rack position chart" at right for more information.
- **To sear meat**, place broiler pan at one of the higher rack positions so that meat is very near the flame.
- **Small steaks** may be broiled in the higher rack positions.
- **To cook large steaks** and other thick cuts of meat well done, move them to a lower rack position after searing.
- **After broiling**, remove the broiler pan from the oven when you remove the food. Drippings will bake on the pan if you leave it in the heated oven.

Broiling rack position chart

RACK POSITION FROM BOTTOM	FOOD
4	Rare steaks and fish
3	Medium and well-done steaks and hamburgers; well-done foods such as chicken, lobster, ham slices and pork chops

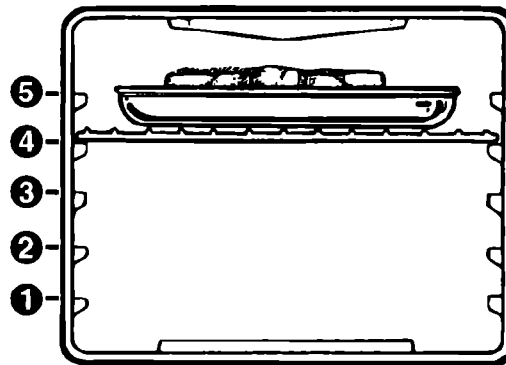

⚠ WARNING

Fire Hazard

- Place meat the correct distance from the burner. Meat placed too close to the burner could spatter, smoke, burn or catch fire during broiling.
- To ensure adequate grease drainage, do not use cookie sheets or similar pans for broiling. Also, covering the broiler grid with foil is not recommended. Poor drainage of grease could result in fire.

Energy saving tips

Although the energy used for cooking is usually a very small percentage of the total energy used in the home, cooking energy can be used efficiently. Here are some tips to help you save energy when using your cooking product:

- **Use** pans with flat bottoms, straight sides and tight-fitting lids.
- **Cook** with a minimum of liquid or fat to help shorten cooking time.
- **Preheat** pans only when recommended and for the shortest time possible.
- **Start** food on higher heat settings, then set surface burner control on low to finish cooking.
- **Use** the more efficient surface burners instead of the oven when possible.
- **Turn on** the surface burner only after placing filled pan on the burner grate.
- **“Oven peeking”** may cause heat loss, longer cooking times and unsatisfactory baking results. Rely on your timer to keep track of the cooking time.
- **Bake** cakes, pies or cookies when oven is warm. Best time to bake is right after a meal has been cooked in oven.
- **Preheat** the oven no longer than necessary.
- **Plan** your meals for the most efficient use of the range. When using the oven to cook one food, try to cook the rest of the meal in it also.
- **Do not preheat** when broiling, roasting or cooking items such as casseroles.
- **Keep burner pans** clean for best heat reflection.

Using the electronic MEALTIMER™ control

The electronic MEALTIMER control will turn the oven on and off at times you set, even when you are not around.

Delayed time baking/roasting is ideal for foods which do not require a preheated oven, such as meats and casseroles. **Do not use delayed time cooking for cakes, cookies, etc. – undercooking will result.**

This section discusses two methods for starting baking/roasting now and stopping automatically later, and three methods for starting and stopping baking/roasting automatically. Read this section carefully to choose which method(s) is best for you.

Before using the electronic MEALTIMER control, make sure the clock is set to the correct time of day. (See “Setting the clock” on page 12.)

To start baking/roasting now and stop automatically

Method 1–Using Cook Time:

1. **Position** the oven rack(s) properly and **put** food in the oven.

USING YOUR RANGE

2. **Push** the Bake pad to enter the Bake mode. **Use** the Temp pad(s) to set the desired temperature. **Push** ▲ to raise the temperature or ▼ to lower the temperature in 5°F increments. Use these pads until the desired temperature shows on the small display.

After you have set the desired temperature, the display will show the set temperature and the time of day. BAKE will light up.



3. **Push** the Cook Time pad. "0:00" with the colon flashing and COOK TIME will show on the display.
4. **Use** the Hour and Minute pads to set the desired cooking time. **Push** the "up" (▲) or "down" (▼) pad(s) until the correct time shows on the display.

This example shows a desired baking/roasting time of 30 minutes.

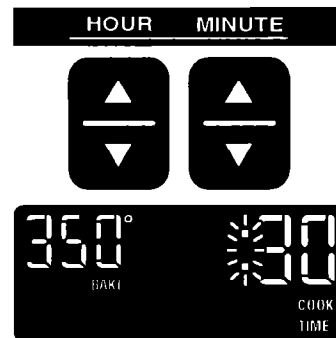

5. **Push** the Start/Enter pad. "Lo", HEAT, BAKE, TIMED and the set cook time will show on the display to indicate that the oven is heating.

NOTE: The display will show "door" and a tone will sound once a minute for 5 minutes if the door is latched when you try to bake/roast.

You can change the temperature or time settings any time after pushing the Start/Enter pad by repeating just Steps 2 through 4.

6. **The display** will count down the baking/roasting time in minutes.



USING YOUR RANGE

7. When the baking/roasting time is completed, the oven will turn off automatically, four tones will sound, and "End" will show on the display. You will also hear four 1-second tones every minute until you push the Off/Cancel pad.

NOTE: To disable reminder tones, push and hold the Cook Time pad for 4 seconds. To reactivate tones, repeat this procedure.



To cancel the MEALTIMER™ control setting:

- Push the Off/Cancel pad to return the display to the time of day.

Method 2—Using Stop Time:

1. Position the oven rack(s) properly and put food in the oven.
2. Push the Bake pad to enter the Bake mode. Use the Temp pad(s) to set the desired temperature. Push ▲ to raise the temperature or ▼ to lower the temperature in 5°F increments. Use these pads until the desired temperature shows on the small display.

After you have set the desired temperature, the display will show the set temperature and the time of day. BAKE will light up.

3. Push the Stop Time pad. The time of day with the colon flashing and STOP TIME will show on the display.
4. Use the Hour and Minute pads to set the desired stop time. Push the "up" (▲) or "down" (▼) pad(s) until the correct time shows on the display.

This example shows a desired stop time of 2 o'clock. This provides a 2-hour cook time (the difference between the time of day and the stop time).

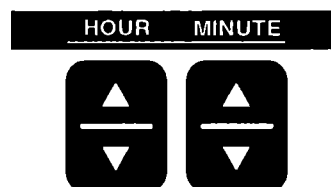

5. Push the Start/Enter pad. "Lo", HEAT, TIMED and BAKE will light up on the display to indicate that the oven is heating.

NOTE: The display will show "door" and a tone will sound once a minute for 5 minutes if the door is latched when you try to bake/roast.

You can change the temperature or time settings any time after pushing the Start/Enter pad by repeating just Steps 2 through 4.

6. The display will count down the baking/roasting time in minutes.
7. When the baking/roasting time is completed, the oven will turn off automatically, four tones will sound, and "End" will show on the display. You will also hear four 1-second tones every minute until you push the Off/Cancel pad.

NOTE: To disable reminder tones, push and hold the Cook Time pad for 4 seconds. To reactivate tones, repeat this procedure.

To cancel the MEALTIMER™ control setting:

- Push the Off/Cancel pad to return the display to the time of day.

To delay start and stop automatically

Method 1—Using Cook Time and Delay Start Time:

1. Position the oven rack(s) properly and put food in the oven.
2. Push the Bake pad to enter the Bake mode. Use the Temp pad(s) to set the desired temperature. Push ▲ to raise the temperature or ▼ to lower the temperature in 5°F increments. Use these pads until the desired temperature shows on the small display.

After you have set the desired temperature, the display will show the set temperature and the time of day. BAKE will light up.

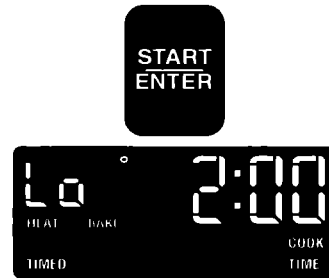

BEEP BEEP BEEP BEEP

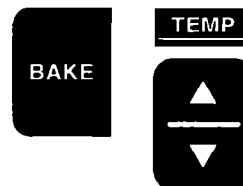

USING YOUR RANGE

3. Push the Cook Time pad. "0:00" with the colon flashing and COOK TIME will show on the display.
4. Use the Hour and Minute pads to set the desired cooking time. Push the "up" (▲) or "down" (▼) pad(s) until the correct time shows on the display.

This example shows a desired baking/roasting time of 30 minutes.

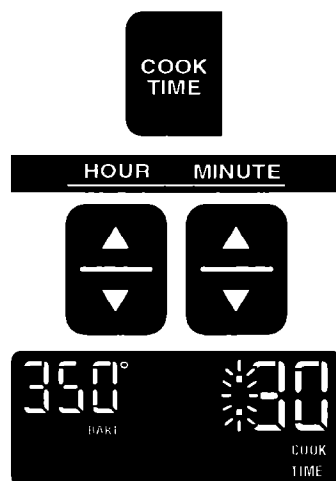

5. Push the Delay Start Time pad. The time of day with the colon flashing will show on the display and START TIME will light up.



6. Use the Hour and Minute pads to set the desired start time. Push the "up" (▲) or "down" (▼) pad(s) until the correct time shows on the display.

This example shows a desired start time of 2 o'clock. The oven will automatically shut off at 2:30 (the set start time plus the set cook time).

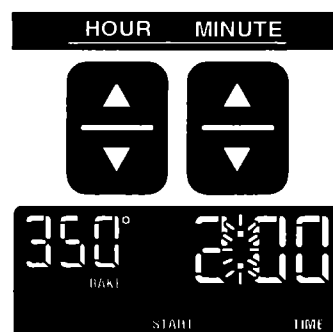

7. Push the Start/Enter pad. DELAY and BAKE will light up on the display to indicate that the oven is programmed to start at a later time.

NOTE: The display will show "door" and a tone will sound once a minute for 5 minutes if the door is latched when you try to bake/roast.

You can change the temperature or time settings any time after pushing the Start/Enter pad by repeating just Steps 2 through 6.



USING YOUR RANGE

8. When the start time is reached, a one-second tone will sound and DELAY will go off. The display will show the set cook time. "Lo", HEAT, TIMED and BAKE will light up on the display to show that the oven is heating. The display will count down the baking/roasting time in minutes.

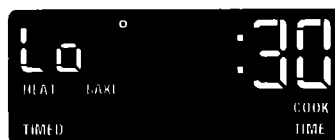

9. When the baking/roasting time is completed, the oven will turn off automatically, four tones will sound, and "End" will show on the display. You will also hear four 1-second tones every minute until you push the Off/Cancel pad.

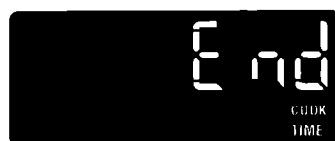

NOTE: To disable reminder tones, push and hold the Cook Time pad for 4 seconds. To reactivate tones, repeat this procedure.

BEEP BEEP BEEP BEEP

To cancel the MEALTIMER™ control setting:

- Push the Off/Cancel pad to return the display to the time of day.



Method 2—Using Delay Start Time and Stop Time:

1. Position the oven rack(s) properly and put food in the oven.
2. Push the Bake pad to enter the Bake mode. Use the Temp pad(s) to set the desired temperature. Push ▲ to raise the temperature or ▼ to lower the temperature in 5°F increments. Use these pads until the desired temperature shows on the small display.

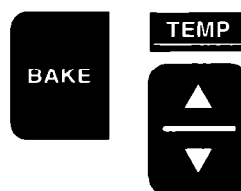

After you have set the desired temperature, the display will show the set temperature and the time of day. BAKE will light up.



3. Push the Delay Start Time pad. The time of day with the colon flashing will show on the display and START TIME will light up.



USING YOUR RANGE

4. Use the Hour and Minute pads to set the desired start time. Push the “up” (▲) or “down” (▼) pad(s) until the correct time shows on the display.

This example shows a desired start time of 2 o'clock.

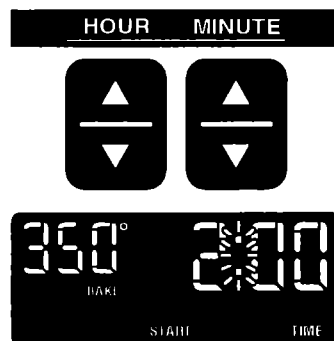

5. Push the Stop Time pad. The time of day with the colon flashing will show on the display and STOP TIME will light up.



6. Use the Hour and Minute pads to set the desired stop time. Push the “up” (▲) or “down” (▼) pad(s) until the correct time shows on the display.

This example shows a desired stop time of 2:30. This provides a cook time of 30 minutes (the difference between the start and stop times).

NOTE: If you do not set a stop time, the colon will flash on the display and STOP and COOK will flash alternately to remind you to program a stop time or a cook time. (See page 21 for instructions on how to set delay start and stop automatically using Cook Time and Delay Start Time.)

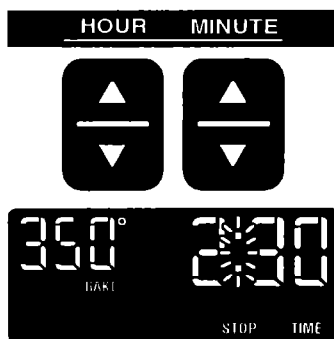

7. Push the Start/Enter pad. DELAY and BAKE will light up on the display to indicate that the oven is programmed to start at a later time.

NOTE: The display will show “door” and a tone will sound once a minute for 5 minutes if the door is latched when you try to bake/roast.

You can change the temperature or time settings any time after pushing the Start/Enter pad by repeating just Steps 2 through 6.

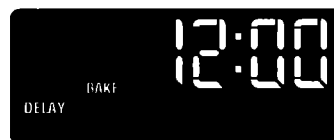

8. When the start time is reached, a one-second tone will sound and DELAY will go off. The display will show the set cook time. "Lo", HEAT, TIMED and BAKE will light up on the display to show that the oven is heating. The display will count down the baking/roasting time in minutes.



9. When the baking/roasting time is completed, the oven will turn off automatically, four tones will sound, and "End" will show on the display. You will also hear four 1-second tones every minute until you push the Off/Cancel pad.

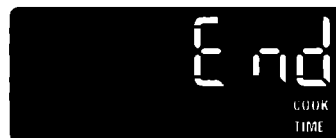

NOTE: To disable reminder tones, push and hold the Cook Time pad for 4 seconds. To reactivate tones, repeat this procedure.



To cancel the MEALTIMER™ control setting:

- Push the Off/Cancel pad to return the display to the time of day.



Method 3—Using Cook Time and Stop Time:

1. Position the oven rack(s) properly and put food in the oven.
2. Push the Bake pad to enter the Bake mode. Use the Temp pad(s) to set the desired temperature. Push ▲ to raise the temperature or ▼ to lower the temperature in 5°F increments. Use these pads until the desired temperature shows in the small display. After you have set the desired temperature, the display will show the set temperature and the time of day. BAKE will light up.

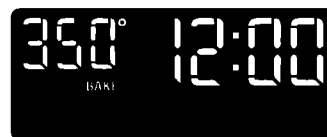
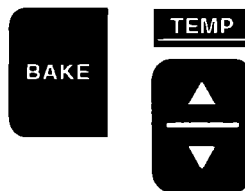

3. Push the Cook Time pad. "0:00" with the colon flashing and COOK TIME will show on the display.



USING YOUR RANGE

- Use the Hour and Minute pads to set the desired cooking time. Push the “up” (▲) or “down” (▼) pad(s) until the correct time shows on the display.

This example shows a desired baking/roasting time of 30 minutes.

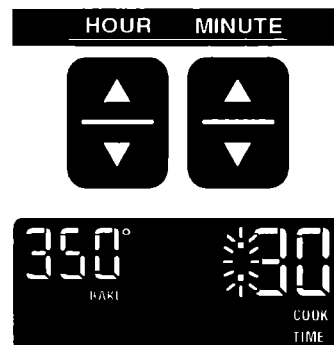

- Push the Stop Time pad. The time of day with the colon flashing will show on the display and STOP TIME will light up.

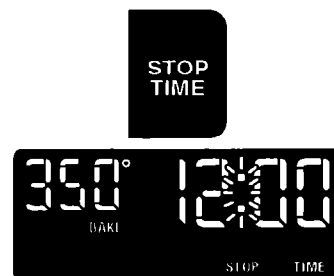

- Use the Hour and Minute pads to set the desired stop time. Push the “up” (▲) or “down” (▼) pad(s) until the correct time shows on the display.

This example shows a desired stop time of 2:30. The oven will automatically start cooking at 2:00 (the set stop time minus the set cook time).

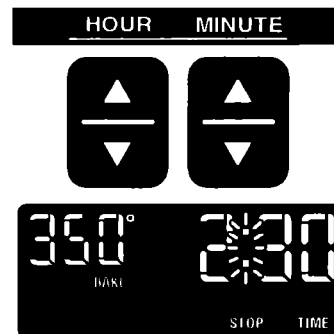

- Push the Start/Enter pad. DELAY and BAKE will light up on the display to indicate that the oven is programmed to start at a later time.

NOTE: The display will show “door” and a tone will sound once a minute for 5 minutes if the door is latched when you try to bake/roast.

You can change the temperature or time settings any time after pushing the Start/Enter pad by repeating just Steps 2 through 6.



8. When the start time is reached, a one-second tone will sound and DELAY will go off. The display will show the set cook time. "Lo", HEAT, TIMED and BAKE will light up on the display to show that the oven is heating. The display will count down the baking/roasting time in minutes.

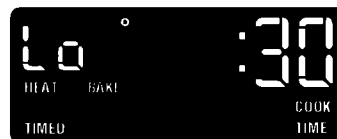

9. When the baking/roasting time is completed, the oven will turn off automatically, four tones will sound, and "End" will show on the display. You will also hear four 1-second tones every minute until you push the Off/Cancel pad.



NOTE: To disable reminder tones, push and hold the Cook Time pad for 4 seconds. To reactivate tones, repeat this procedure.



To cancel the MEALTIMER™ control setting:

- Push the Off/Cancel pad to return the display to the time of day.



⚠ WARNING

To avoid sickness and food waste when using the MEALTIMER™ control:

- Do not let most UNFROZEN food stand for more than two hours before cooking starts.
- Do not allow food to remain in oven for more than two hours after the end of cooking cycle.

NOTE: Do not use foods that will spoil while waiting for cooking to start. Such foods are: dishes with milk or eggs, cream soups and cooked meats or fish. Also, foods containing baking powder or yeast will not rise properly when cooked using delay start.

The oven vent

Hot air and moisture escape from the oven through a vent located in lower part of backguard. The vent is needed for air circulation. **Do not block the vent.** Poor baking/roasting will result.

NOTE: Never store plastics, paper or other items that could melt or burn near the oven vent, or any of the surface burners.

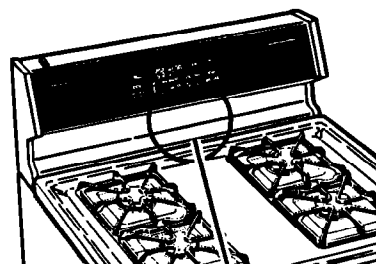

Oven vent

⚠ WARNING

Burn Hazard

When the oven is ON, pans and pan handles left near the oven vent could become hot enough to burn the user and to melt plastics. Use potholders to move pans.

The storage drawer

You can remove the storage drawer to make it easier to clean under the range and to check for installation of the anti-tip floor brackets. **Use care when handling the drawer.**

Removing the storage drawer:

1. **Empty** drawer before removing. **Pull** drawer straight out to the first stop. **Lift** front and **pull out** to the second stop.
2. **Lift** back slightly and **slide** drawer all the way out.

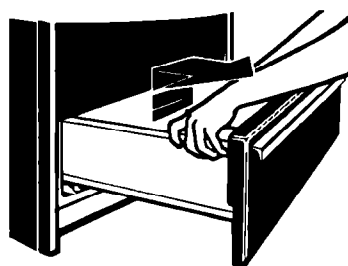

Replacing the storage drawer:

1. **Fit** ends of drawer slide rails into the drawer guides on both sides of opening.
2. **Lift** drawer front and **push in** until metal stops on drawer slide rails clear white stops on drawer guides. **Lift** drawer front again to clear second stop and **slide** drawer closed.

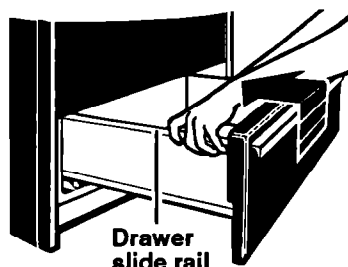

The anti-tip brackets

The range will not tip during normal use. However, tipping can occur if you apply too much force or weight to the open door without the anti-tip brackets properly secured.

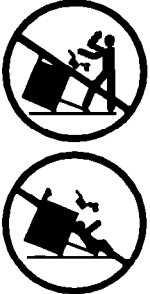
	<p style="text-align: center;">⚠ WARNING</p> <p style="text-align: center;">Personal Injury Hazard</p> <ul style="list-style-type: none"> • To reduce risk of range tipping over, secure range with properly installed anti-tip brackets supplied with range. • If range is moved for cleaning or service, check that anti-tip devices are engaged before using range. <p>Failure to follow the above precautions could result in personal injury.</p>
---	--

To verify the anti-tip brackets are engaged:

- **Grasp** rear of range and carefully try to tilt forward. If anti-tip brackets are attached to floor with screws and rear leveling legs are positioned under brackets (one for each rear leveling leg), range should not tilt forward.

OR

- **Remove** the storage drawer. (See page 28.)
- **Make sure** the rear leveling legs are positioned under brackets.
- **See** Installation Instructions for further details.

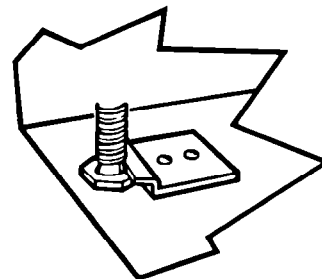

Using The Self-Cleaning Cycle

In This Section

	Page		Page
How the cycle works	30	Setting the controls	31
Before you start	30	Special tips	34

The Self-Cleaning cycle saves you from the toil and mess that often come with hand-cleaning the oven interior. Like with the other functions of your range, you operate the Self-Cleaning cycle with the easy-to-use electronic control. Please review the instructions in this section to keep your oven spotless.

How the cycle works

The Self-Cleaning cycle uses very high heat to burn away soil and grease. During the cycle, the oven gets much hotter than it does for normal baking or broiling. This high heat breaks up the soil or grease and burns it away.

Your oven is preset for a 3-hour Self-Cleaning cycle. However, you can adjust the cycle time to the amount of soil in your oven. You can set the cycle anywhere between 2 and 4 hours. (See "Setting the controls" on page 31.)

The graph at the right is representative of a normal, 3-hour Self-Cleaning cycle. Note that the heating stops when the 3-hour setting is up, but it takes longer for the oven to cool enough to unlock.

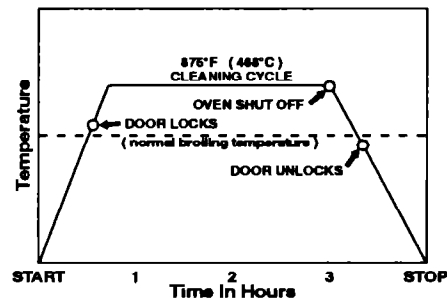

Before you start

Before you start the Self-Cleaning cycle, make sure you:

- Hand-clean the areas shown. They do not get hot enough during the cleaning cycle for soil to burn away. Use hot water and detergent or a soapy steel-wool pad for cleaning.

NOTE: DO NOT clean, move or bend the seal. Poor cleaning, baking and roasting may result.

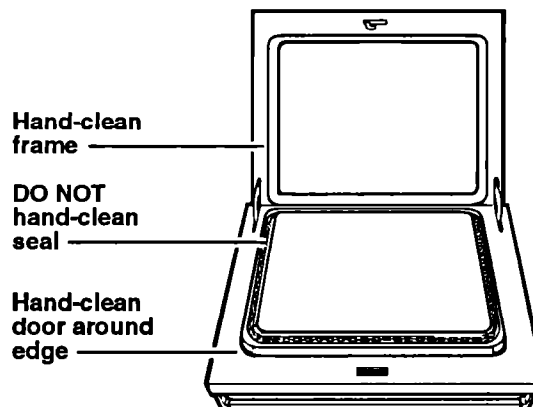

USING THE SELF-CLEANING CYCLE

- **Remove any pots and pans** being stored in the oven.

NOTE: You can clean the broiler pan and grid in the oven if you have first removed most of the soil by hand-cleaning or in a dishwasher. If most of the soil is not removed, too much smoking will occur.

- **Wipe out any loose soil or grease.** This will help reduce smoke during the cleaning cycle.
- **Remove the oven racks from the oven if you want them to remain shiny.** You can clean the oven racks in the Self-Cleaning cycle, but they will become harder to slide. (See page 39.) If you clean racks in the Self-Cleaning cycle, place them on the 2nd and 4th rack guides. (Guides are counted from bottom to top.)
- **Heat and odors are normal during the Self-Cleaning cycle.** Keep the kitchen well ventilated by opening a window or by turning on a vent hood or other kitchen vent during the cycle.

⚠ WARNING

Personal Injury and Product Damage Hazard

- Do not touch the oven during the Self-Cleaning cycle. It could burn you.
- Do not use commercial oven cleaners in your oven. Cleaners could produce hazardous fumes or damage the porcelain finish.
- Do not leave any foil in the oven during the Self-Cleaning cycle. Foil could burn or melt and damage the oven surface.

NOTES:

- **Do not force the Lock Lever.** You could bend or break it. The lever is designed to stay locked until the oven is cool enough to safely open. Wait until it moves freely.
- **Do not block the vent during the Self-Cleaning cycle.** Air must move freely for best cleaning results.
- **Do not leave plastic utensils near the vent.** They may melt.
- **Do not use the oven light during the Self-Cleaning cycle.** Use during the Self-Cleaning cycle will shorten the life of the bulb.

Setting the controls

1. **Make sure** the clock is set to the correct time of day. (See "Setting the clock" on page 12.)
2. **Move** the Lock Lever all the way to the right—the Clean position.

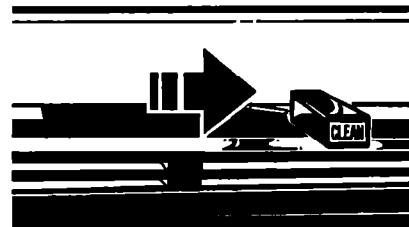

3. **Set** the cleaning cycle.

To start cleaning immediately:

Push the Clean pad. A 3-hour Self-Cleaning cycle will be set automatically. "3:00" with the colon flashing will show on the large display and "cln" will show on the small display. TIME CLEAN (on right side) and CLEAN (on left side) will light up.



USING THE SELF-CLEANING CYCLE

If a cleaning cycle other than 3 hours is desired, use the Hour and Minute pads to set the desired cleaning time. Push the "up" (▲) or "down" (▼) pad(s) until a time between 2-4 hours shows on the display.

- Use 2 hours for light soil.
- Use 3-4 hours for moderate to heavy soil.

Push the Start/Enter pad. TIMED and HEAT will light up on the display to indicate that the oven is programmed for the Self-Cleaning cycle.

NOTE: The display will show "door" and a tone will sound once a minute for 5 minutes if the door is not latched.

Skip to Step 4.

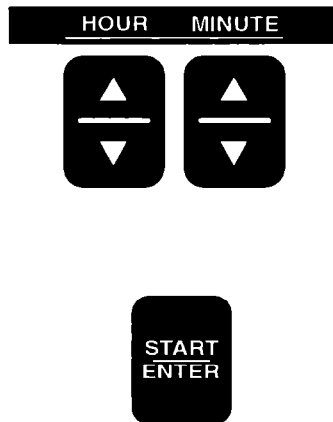

To delay the start using Stop Time:

Push the Clean pad. Push the Stop Time pad. STOP, TIME, CLEAN and "cln" will light up.

Use the Hour and Minute pads to set the desired stop time. Push the "up" (▲) or "down" (▼) pad(s) until the correct time shows on the display. The oven will automatically compute the delay start time by subtracting the set cleaning time from the set stop time.

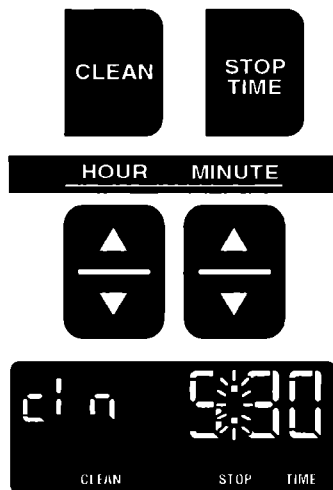

Push the Start/Enter pad. DELAY, CLEAN and the time of day will light up on the display to indicate that the oven is programmed to start the Self-Cleaning cycle at a later time.

Skip to Step 4.



USING THE SELF-CLEANING CYCLE

To delay the start using Delay Start Time:

Push the Clean pad. Push the Delay Start Time pad. START, TIME, CLEAN and "cln" will light up.

Use the Hour and Minute pads to set the desired start time. Push the "up" (▲) or "down" (▼) pad(s) until the correct time shows on the display.

Push the Start/Enter pad. DELAY, CLEAN and the time of day will light up on the display to indicate that the oven is programmed to start the Self-Cleaning cycle at a later time.

After the start time has been set, the large display will go back to showing the current time of day. DELAY and CLEAN will stay on. When the start time is reached, DELAY will go off, TIMED, HEAT, CLEAN and CLEAN TIME will light up and the oven will start to clean.

4. After the Self-Cleaning cycle is started, LOCKED lights up on the display when the oven temperature goes above normal baking/roasting temperatures. The Lock Lever must not be moved and the door cannot be opened when LOCKED is on.

5. After the Self-Cleaning cycle is completed, the time of day will show on the display.

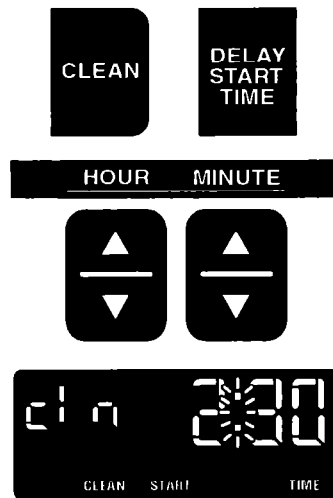

USING THE SELF-CLEANING CYCLE

6. When the oven reaches normal baking/roasting temperatures, LOCKED goes off and "End" and CLEAN TIME come on. Move the Lock Lever back to the left. **DO NOT FORCE IT.** Wait until it moves easily.

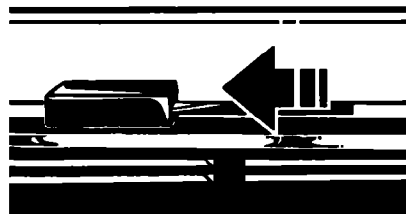

To stop the Self-Cleaning cycle at any time:

1. Push the Off/Cancel pad.
2. When LOCKED goes off, move the Lock Lever back to the left. **DO NOT FORCE IT.** Wait until it moves easily.



Special tips

- Keep the kitchen well ventilated during the Self-Cleaning cycle to help get rid of heat, odors and smoke.
- After the oven is cool, wipe up any residue or ash with a damp cloth or sponge. If any spots remain, clean with a mild abrasive cleanser or cleaning sponge.
- Clean the oven before it gets heavily soiled. Cleaning a very soiled oven takes longer and results in more smoke than usual.
- If the Self-Cleaning cycle does not get the oven as clean as you expected, the cycle may not have been set long enough or you may not have prepared the oven properly. Set the Self-Cleaning cycle longer the next time and hand-clean areas noted on page 30.

Caring For Your Range

In This Section		Page	Page
Surface burner grates	35	Cleaning chart	38
Surface burners and cooktop	36	The oven light	40

Your range is designed for easy care. You can do most cleaning with items found around your home. Cleaning your range whenever spills or soiling occurs will help to keep it looking and operating like new.

⚠ WARNING

Burn, Electrical Shock, Fire and Explosion Hazard

- Make sure all controls are OFF and the range is cool before cleaning.
- Do not use oven cleaners, bleach or rust removers.
- Do not obstruct the flow of combustion and ventilation air.
- Keep appliance area clear and free of combustible materials, gasoline and other flammable vapors and liquids.

Failure to follow these guidelines could result in burns, electrical shock, fire or explosion.

Surface burner grates

1. **Make sure** all surface burners are off and the surrounding parts are cool.
2. **Lift off** the surface burner grates.
3. **Wash** the grates with warm, soapy water or in a dishwasher. **Use** a nonabrasive, plastic scrubbing pad for cooked-on foods. **Rinse** and **dry** well.
4. **Replace** burner grates.

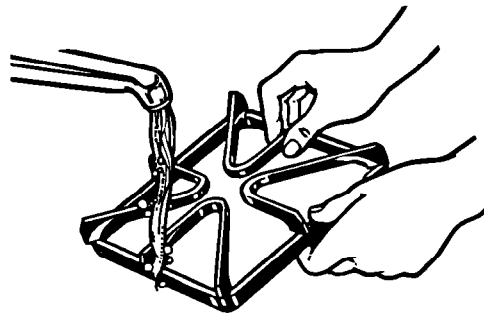

Surface burners and cooktop

The cooktop and burner box areas are specially designed to make cleaning easier. Because the four burners are sealed, cleanups are easy and convenient.

To clean the cooktop, wipe with a damp sponge and dry.

Cleaning the contoured well areas

The contoured well is a recessed area located around each burner.

If spills occur in contoured well section:

1. Blot up spill with a paper towel.
2. Wipe with a clean, damp sponge.
3. Dry.

NOTE: When cleaning the cooktop area or around the burner base, use care to prevent damage to the ignitor. If a cleaning utensil should catch it, the ignitor could be damaged or broken. If the ignitor is damaged or broken, the surface burner will not light. When cleaning the cooktop, leave the burner cap in place to protect the ignitor from possible damage.

Cleaning the surface burners

- The burner caps should be routinely removed and cleaned. Always clean burner caps after a spillover. Keeping the burner caps clean prevents improper ignition and an uneven flame.
- For proper flow of gas and ignition of the burner, DO NOT ALLOW SPILLS, FOOD, CLEANING AGENTS OR ANY OTHER MATERIAL TO ENTER THE GAS TUBE OPENING.
- Gas must flow freely through the small hole in the brass orifice for the burner to light properly. This area must be free of any soil and be kept protected from boilovers or spillovers. ALWAYS keep the burner caps in place whenever a surface burner is in use.

CAUTION

Product Damage Hazard

Do not remove the cooktop.
Doing so could result in product damage.

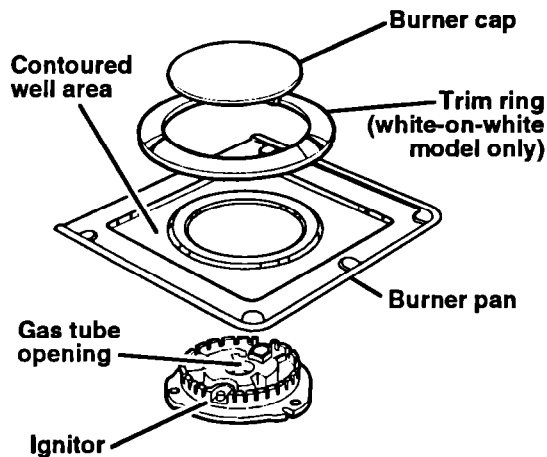

CARING FOR YOUR RANGE

- **Occasionally check the burner flames** for proper size and shape as shown. A good flame is blue in color. If flames are uneven, you may need to clean the burners.

To clean burners:

1. **Pull the burner cap straight up** from the burner base.
2. **Remove the trim ring** (if equipped) and burner pan.
3. **Clean burner cap, trim ring and burner pan** with warm, soapy water and a sponge. You can also clean with a nonabrasive scrubbing pad or cleanser. **Do not clean burner cap, trim ring or burner pan in dishwasher or self-cleaning oven.**
4. **If the gas tube opening or the orifice, located inside the opening, has become soiled or clogged, use a cotton swab or a soft cloth to clean the area.**
5. **If ports are clogged, clean with a straight pin. Do not enlarge or distort port. Do not use a wooden toothpick. If adjustment is needed, call a qualified technician for service.**
6. **After cleaning the gas tube opening and ports, replace the burner pan, trim ring** (if equipped) and burner cap. (Burner pan and trim ring must be replaced over burner base before replacing burner cap. Do not operate burners without burner pan and trim ring in place.) **To replace burner cap, make sure cap is properly aligned and leveled. Find the recessed locating tabs on the burner cap** (see illustration) and **place cap over the white ignitor in the burner base.**
7. **Turn on the burner to determine if it will light. If the burner does not light after cleaning, contact an authorized Whirlpool® service technician. Do not service the sealed burner yourself.**

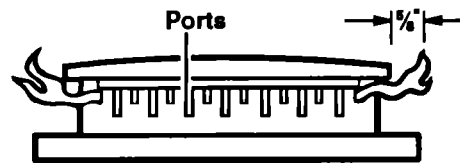

Typical surface burner flame at highest setting

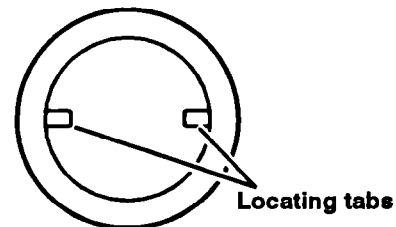

CARING FOR YOUR RANGE

Cleaning chart

Use the following table to help you clean your range.

PART	WHAT TO USE	HOW TO CLEAN
Control knobs	Sponge and warm, soapy water	<ul style="list-style-type: none"> • Turn knobs to OFF and pull straight away from control panel. • Wash, rinse and dry thoroughly. Do not soak. • Do not use steel wool or abrasive cleansers. They may damage the finish of the knobs. • Replace knobs. Make sure all knobs point to OFF.
Control panels	Sponge and warm, soapy water OR Paper towel and spray glass cleaner	<ul style="list-style-type: none"> • Wash, rinse and dry thoroughly. • Do not use steel wool or abrasive cleansers. They may damage the finish. • Do not spray cleaner directly on panel. Apply cleaner to paper towel. <p>NOTE: Make sure you have not turned the oven on when cleaning panel. If you have, push the Off/Cancel pad.</p>
Exterior surfaces (other than control panels)	Sponge and warm, soapy water	<ul style="list-style-type: none"> • Wash, rinse and dry thoroughly. • Use nonabrasive, plastic scrubbing pad on heavily soiled areas. • Do not use abrasive or harsh cleansers. They may damage the finish. <p>NOTE: Do not allow foods containing acids (such as vinegar, tomato or lemon juice) to remain on surface. Acids may remove the glossy finish. Also wipe up milk or egg spills when cooktop is cool.</p>
Surface burners, grates, caps, trim rings, and burner pans	Warm, soapy water and sponge or non-abrasive, plastic scrubbing pad OR Dishwasher (for grates)	<ul style="list-style-type: none"> • See pages 35-37 for cleaning instructions.
Broiler pan and grid (clean after each use)	Steel-wool pad and warm, soapy water	<ul style="list-style-type: none"> • Wash, rinse and dry thoroughly.

CARING FOR YOUR RANGE

PART	WHAT TO USE	HOW TO CLEAN
Oven racks	Steel-wool pad and warm, soapy water OR The Self-Cleaning cycle	<ul style="list-style-type: none"> • Wash, rinse and dry thoroughly. <p style="text-align: center;">OR</p> <ul style="list-style-type: none"> • Leave in oven during Self-Cleaning cycle. <p>NOTE: Racks will permanently discolor and become harder to slide if left in oven during Self-Cleaning cycle. Apply a small amount of vegetable oil to the side rungs to aid sliding.</p>
Oven door glass	Paper towel and spray glass cleaner OR Warm, soapy water and a nonabrasive, plastic scrubbing pad	<ul style="list-style-type: none"> • Make sure oven is cool. • Follow directions provided with the cleaner. • Wash, rinse and dry thoroughly.
Oven cavity	Self-Cleaning cycle	<ul style="list-style-type: none"> • See "Using The Self-Cleaning Cycle" on pages 30-34.

The oven light

The oven light will come on when you open the oven door. **To turn on the light when the oven door is closed, press the Oven Light Switch on the backguard.**

⚠ WARNING

Electrical Shock and Personal Injury Hazard

- Make sure oven and light bulb are cool and power to the range has been turned off before replacing the light bulb. Failure to do so could result in electrical shock or burns.
- The bulb cover must be in place when using the oven. The cover protects the bulb from breaking, and from high oven temperatures. Because bulb cover is made of glass, be careful not to drop it. Broken glass could cause injury.

To replace the oven light:

1. **Unplug** appliance or **disconnect** at the main power supply.
2. **Remove** the glass bulb cover in the back of the oven by pushing the wire holder to the side and pulling out bulb cover.
3. **Remove** the light bulb from its socket. **Replace** the bulb with a 40-watt appliance bulb.
4. **Replace** the bulb cover and **snap** the wire holder into place. **Plug in** appliance or **reconnect** at the main power supply.

NOTE: The oven light should not be used during the Self-Cleaning cycle. Use during the Self-Cleaning cycle will shorten the life of the bulb.

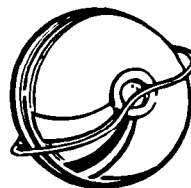
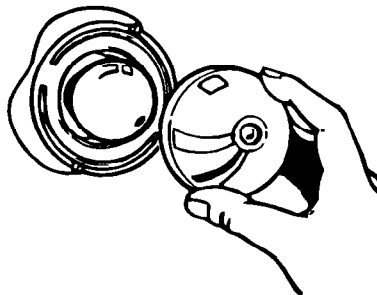

If You Need Assistance Or Service

This section is designed to help you save the cost of a service call. Part 1 of this section outlines possible problems, their causes, and actions you can take to solve each problem. Parts 2 and 3 tell you what to do if you still need assistance or service. When calling our toll-free telephone number for help or calling for service, please provide a detailed description of the problem, your appliance's complete model and serial numbers and the purchase date. (See page 2.) This information will help us respond properly to your request.

1. Before calling for assistance ...

Performance problems often result from little things you can find and fix without tools of any kind. Please check the chart below for problems you can fix. It could save you the cost of a service call.

PROBLEM	POSSIBLE CAUSE	SOLUTION
Nothing will operate	<p>The power cord is not plugged into a live circuit with proper voltage.</p> <p>Range is not properly connected to gas supply.</p> <p>A household fuse has blown or a circuit breaker has tripped.</p> <p>Controls are not set correctly.</p> <p>The flow of combustion and/or ventilation air to the range is blocked.</p>	<p>Plug the power cord into a live circuit with proper voltage. (See Installation Instructions.)</p> <p>Contact an authorized Whirlpool® service technician to reconnect range to gas supply. (See Installation Instructions.)</p> <p>Replace household fuse or reset circuit breaker.</p> <p>Reset controls, if needed.</p> <p>Remove blockage to airflow to and around range.</p>
The oven will not operate	<p>The electronic control has not been set correctly.</p> <p>A delayed start time has been set.</p>	<p>Refer to pages 14-27 for setting the electronic control.</p> <p>Wait for the start time to be reached.</p>
Burner fails to light	<p>The power cord is not plugged into a live circuit with proper voltage.</p> <p>A household fuse has blown or a circuit breaker has tripped.</p> <p>Burner ports are clogged.</p>	<p>Plug the power cord into a live circuit with proper voltage. (See Installation Instructions.)</p> <p>Replace household fuse or reset circuit breaker. In case of prolonged power failure, manually light burners (see page 8).</p> <p>Clean with a straight pin (see page 37).</p>

continued on next page

IF YOU NEED ASSISTANCE OR SERVICE

PROBLEM	POSSIBLE CAUSE	SOLUTION
Burner flames are uneven	Burner ports are clogged.	Clean with a straight pin (see page 37). If this fails, call an authorized Whirlpool® service technician for service.
Burner makes popping noise when on	Burner is wet from washing.	Let dry.
Control knob(s) will not turn	You are not pushing in before turning.	Push control knob(s) in before turning to a setting.
Self-Cleaning cycle will not operate	The range clock does not show the correct time of day. The Lock Lever is not in the CLEAN position—all the way to the right. A delayed start time has been set.	Reset clock to show the correct time of day. (See page 12.) Move Lock Lever all the way to the right. Wait for the start time to be reached.
Cooking results are not what you expected	The range is not level. The oven temperature seems too low or too high. The oven was not preheated as the recipe calls for. The recipe has never been tested or is not from a reliable source. The pans are not the type or size recommended in the recipe. There is not proper air circulation around pan when baking. Flame size does not fit the cooking utensil being used. When broiling, you have not completely closed the oven door.	Level range. (See Installation Instructions.) Adjust the oven temperature control. (See "Adjusting the oven temperature control" on page 15.) Preheat oven if called for in recipe. Use only tested recipes from a reliable source. Refer to a reliable cookbook for recommended pan type and size. Allow 1½ to 2 inches (4-5 cm) on all sides of the pans for air circulation. There must be a minimum space of 1 inch (2.5 cm). Adjust flame size to fit cooking utensil. Completely close oven door.

IF YOU NEED ASSISTANCE OR SERVICE

PROBLEM	POSSIBLE CAUSE	SOLUTION
The display shows "PF"	There has been a power failure.	Reset the clock. (See page 12.)
"F1" or "F3" shows on the display		Call for service. (See Step 3 below.)

2. If you need assistance ...

Call Whirlpool Consumer Assistance Center telephone number. Dial toll-free from anywhere in the U.S.A.:

1-800-253-1301

and talk with one of our trained consultants. The consultant can instruct you in how to obtain satisfactory operation from your appliance or, if service is necessary, recommend a qualified service company in your area.

If you prefer, write to:

Mr. William Clark
Consumer Assistance Representative
Whirlpool Corporation
2000 North M-63
Benton Harbor, MI 49022-2692

Please include a daytime phone number in your correspondence.

3. If you need service ...



Whirlpool has a nationwide network of authorized Whirlpool® service companies.

Whirlpool service

technicians are trained to fulfill the product warranty and provide after-warranty service, anywhere in the United States. To locate the authorized Whirlpool service company in your area, call our Consumer Assistance Center telephone number (see Step 2) or look in your telephone directory Yellow Pages under:

• **APPLIANCE-HOUSEHOLD-MAJOR, SERVICE & REPAIR**

- See: Whirlpool Appliances or Authorized Whirlpool Service
(Example: XYZ Service Co.)

• **WASHING MACHINES & DRYERS, SERVICE & REPAIR**

- See: Whirlpool Appliances or Authorized Whirlpool Service
(Example: XYZ Service Co.)

4. If you need FSP® replacement parts ...

FSP is a registered trademark of Whirlpool Corporation for quality parts. Look for this symbol of quality whenever you need a replacement part for your Whirlpool® appliance. FSP replacement parts will fit right and work right, because they are made to the same exacting specifications used to build every new Whirlpool appliance.

To locate FSP replacement parts in your area, refer to Step 3 above or call the Whirlpool Consumer Assistance Center number in Step 2.

5. If you are not satisfied with how the problem was solved ...

- Contact the Major Appliance Consumer Action Panel (MACAP). MACAP is a group of independent consumer experts that voices consumer views at the highest levels of the major appliance industry.
- Contact MACAP only when the dealer, authorized servicer and Whirlpool have failed to resolve your problem.
Major Appliance Consumer Action Panel
20 North Wacker Drive
Chicago, IL 60606
- MACAP will in turn inform us of your action.

WHIRLPOOL® Gas Range Warranty

LENGTH OF WARRANTY	WHIRLPOOL WILL PAY FOR
FULL ONE-YEAR WARRANTY From Date of Purchase	FSP® replacement parts and repair labor to correct defects in materials or workmanship. Service must be provided by an authorized Whirlpool service company.
WHIRLPOOL WILL NOT PAY FOR	
<p>A. Service calls to:</p> <ol style="list-style-type: none"> 1. Correct the installation of your range. 2. Instruct you how to use your range. 3. Replace house fuses or correct house wiring or plumbing. 4. Replace owner accessible light bulbs. <p>B. Repairs when your range is used in other than normal, single-family household use.</p> <p>C. Pickup and delivery. Your range is designed to be repaired in the home.</p> <p>D. Damage to your range caused by accident, misuse, fire, flood, acts of God or use of products not approved by Whirlpool.</p> <p>E. Repairs to parts or systems caused by unauthorized modifications made to the appliance.</p>	

5/93

WHIRLPOOL CORPORATION SHALL NOT BE LIABLE FOR INCIDENTAL OR CONSEQUENTIAL DAMAGES. Some states do not allow the exclusion or limitation of incidental or consequential damages, so this limitation or exclusion may not apply to you. This warranty gives you specific legal rights, and you may also have other rights which vary from state to state.

Outside the United States, a different warranty may apply. For details, please contact your authorized Whirlpool distributor or military exchange.

If you need service, first see the "If You Need Assistance Or Service" section of this book. After checking "If You Need Assistance Or Service," additional help can be found by calling our Consumer Assistance Center telephone number, 1-800-253-1301, from anywhere in the U.S.A.



Printed on recycled paper—
10% post-consumer waste
50% recovered materials

PART NO. 316000734/4372206 Rev. A

© 1994 Whirlpool Corporation

® Registered Trademark/TM Trademark of Whirlpool, U.S.A.

Printed in U.S.A.